

外形寸法
Outline dimensions

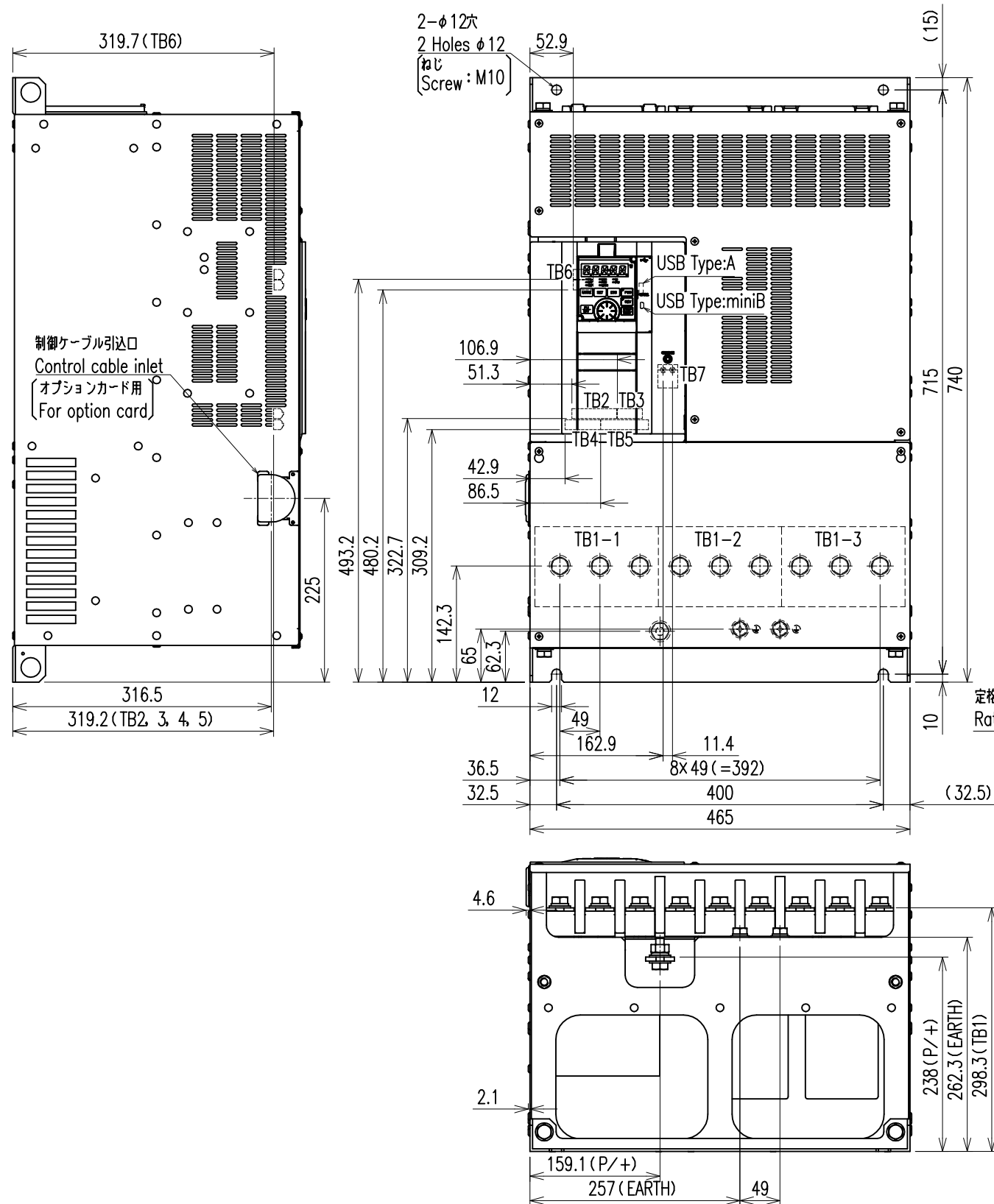

端子配列
Terminal arrangement

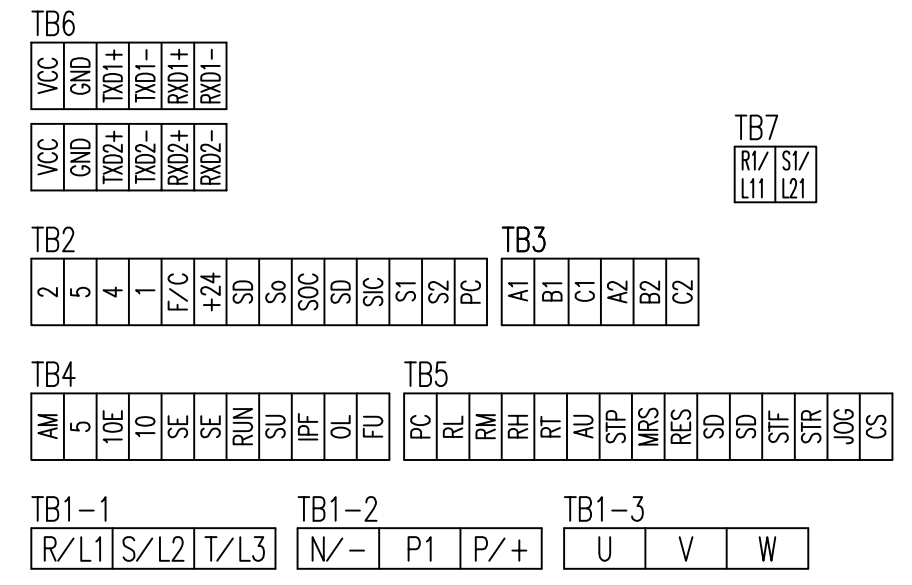

端子ねじサイズ
Terminal screw size

TB1	TB2, 3, 4, 5, 6	TB7	⊕	P/+
M12	-	M4	M8	M12

TB2, 3, 4, 5, 6: スプリングクランプ端子台
Spring clamp terminal block
電線サイズ 0.3~0.75mm²
Wire size AWG 22~18

操作パネルキー配列
OPERATION PANEL key arrangement

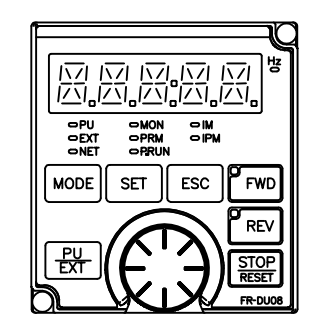

質量
Mass

74kg

(寸法単位 DIM.IN :mm)