

INDUCTION MOTOR

RoHS

(INDOOR USE)

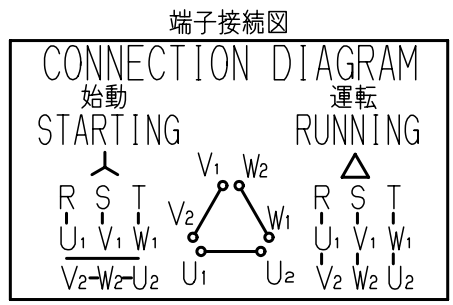
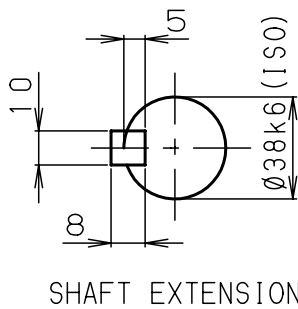
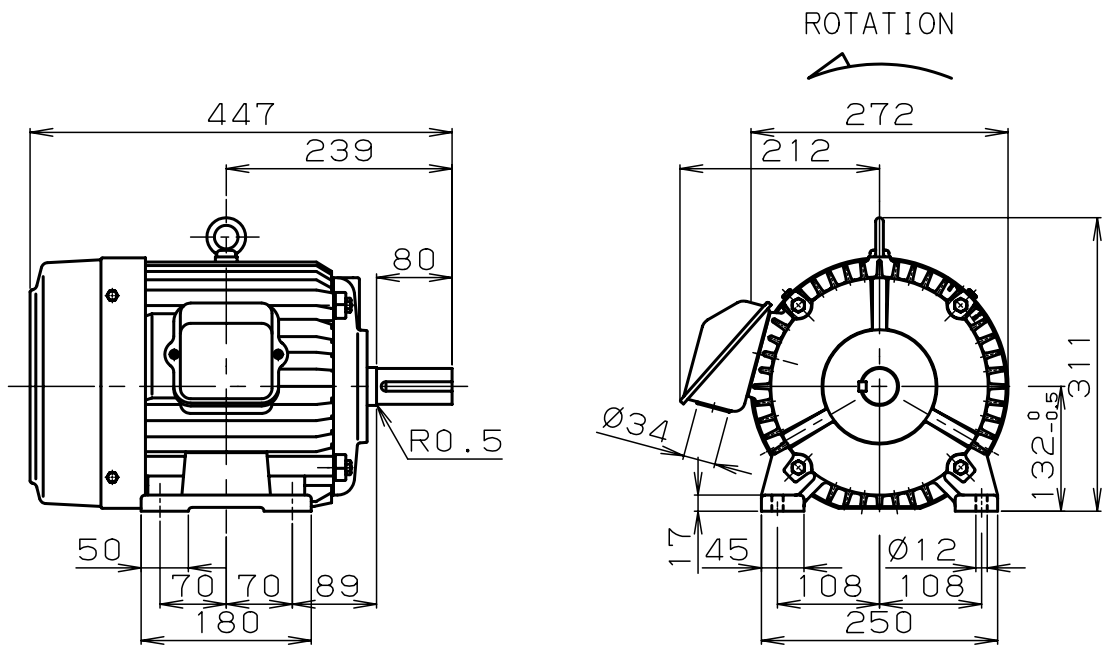

DIMENSIONS IN mm

(出荷時は△に接続して出荷いたします)

MLA8132A	132S	2	3	5.5kW	*1	50/60	2905-2910 3480-3505-3515
TYPE	FRAME	POLES	PH	OUTPUT	VOLT	Hz	min ⁻¹

10-9.8 10-9.3-8.8	S1	B	マンセル N5	IP44	JEC-2137-2000	
A M P	RATING	INSUL	COLOR	PROTECTION	RULE	

*1 400-415
400-440-460

D-END	6308ZZ
N-END	6207ZZ
BEARING	

CUSTOMER :

VIA :

ORDER NO.

APPLICATION :

W. NO.

H0347

	DATE	NAME	APPROVED		Fuji Electric Co.,Ltd.		
DRAWN					DWG. NO	YH550629	
CHECKED							

品番コード MLA1346