

3RD ANGLE METHOD

FINAL
APPROVAL

INDUCTION MOTOR
(INDOOR USE)

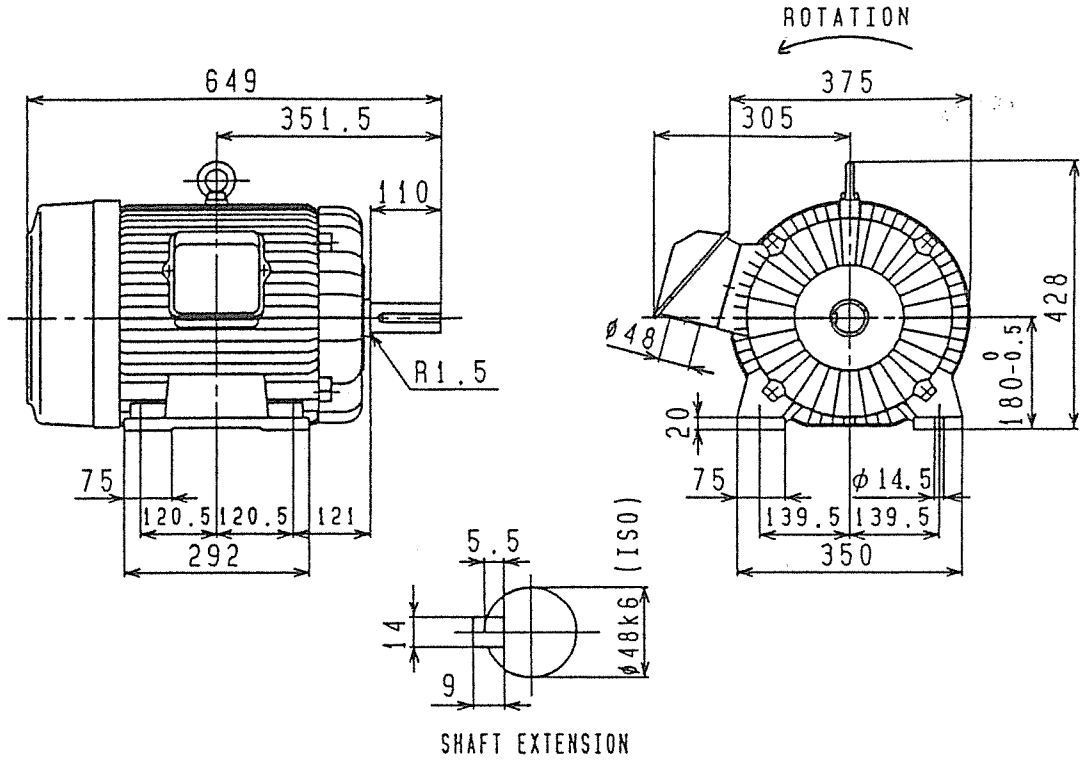

DIMENSIONS IN mm

MLA6185A	180M	4	3	22kW	200/200 220V	50/60	1460/1755 1760
TYPE	FRAME	POLES	PH	OUTPUT	VOLT	Hz	RPM
78/77 71 A	CONT.	B			Jisc 4210		180kg
AMP	RATING	INSUL			PROTECTION		

D-END	6312 ZZ *
N-END	6310 ZZ *
BEARING	

CUSTOMER: _____

VIA: _____

ORDER NO. _____

APPLICATION: _____

W. NO. _____

DATE	NAME	APPROVED	Fuji Electric Co., Ltd.	
DRAWN			DWG. NO.	YH592391a
CHECKED				