

三相誘導電動機 THREE-PHASE INDUCTION MOTOR

出力 OUTPUT (kW)	形 TYPE	式 FORM	定格 RATING	電圧 VOLTAGE (V)	周波数 REQ. (Hz)	同期回転速度 SYNC. SPEED (min <sup>-1</sup> )	極数 POLES	耐熱クラス TH. CLASS	質量 MASS (kg)
適用規格 (RULE)				効率クラス (IE CODE)					

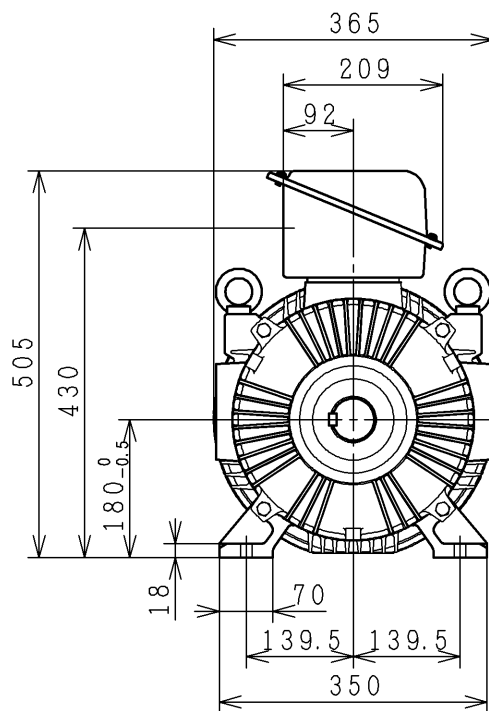

φD
36
45
52
65
78
92

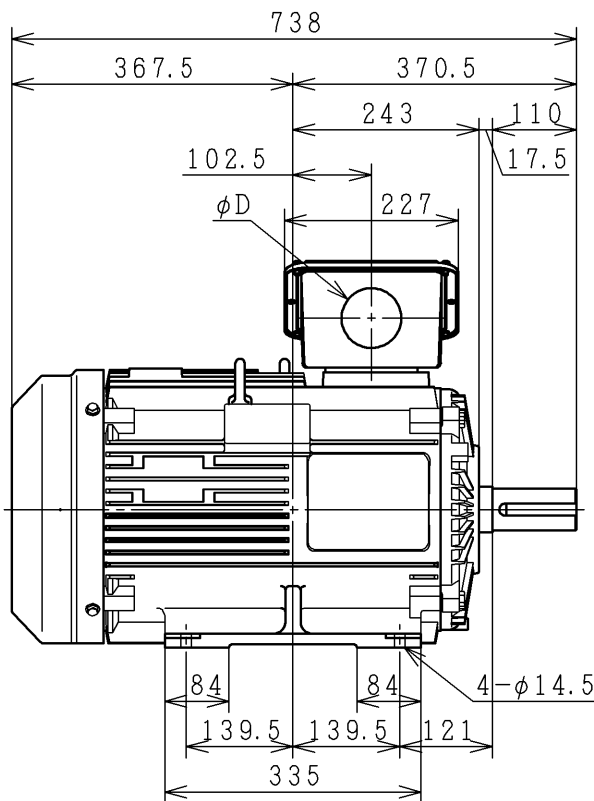
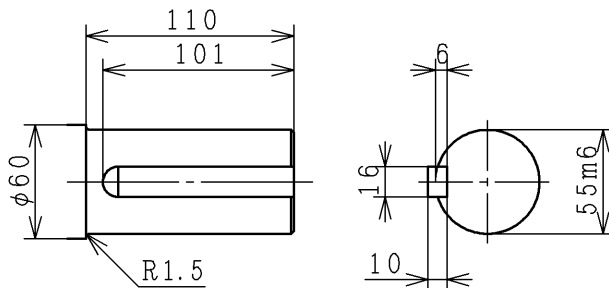

保護方式 (PROTECTION)	塗装色 (COLOR)	PROJECTION
軸受 (BRG.)	反負荷側 (O. S.)	負荷側 (D. S.)



用途 USE \_\_\_\_\_ 付属品 ACCESSORY \_\_\_\_\_

備考 NOTICE

御注文主 CUSTOMER	数量 QTY.	受注番号 ORDER No.	作業番号 WORK No.	REV.
殿				1

DWN. K. Abe	Sep-03-2013	寸法図 DIMENSIONS	Hitachi Industrial Equipment Systems Co., Ltd.	NARASHINO WORKS DWG. No.	SH.
CHKD. M. Amaike	Sep-03-2013			3244R856395	
APPD. M. Amaike	Sep-03-2013				

機種 FRAME SIZE TFOL-180L

