

3RD ANGLE METHOD

FINAL  
APPROVAL

INDUCTION MOTOR

INDOOR USE  
DIRECT COUPLE

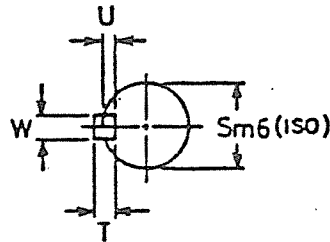
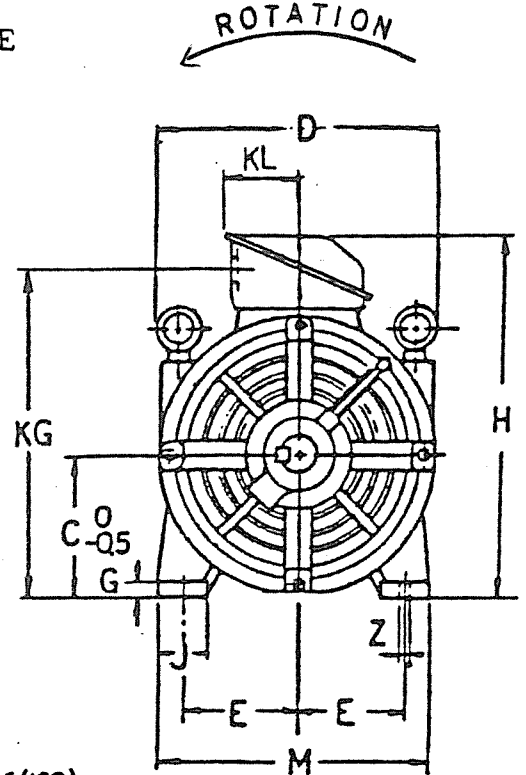
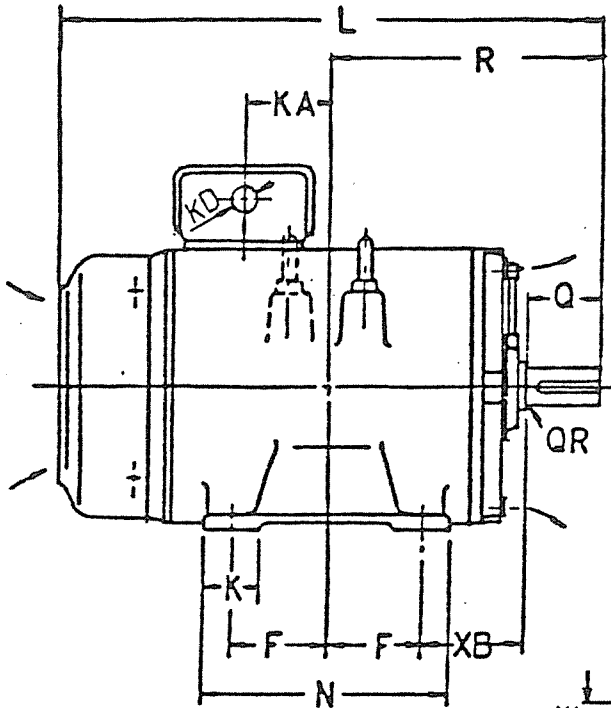

DIMENSIONS IN mm

SHAFT EXTENSION

FRAME	MOTOR												
	C	D	E	F	G	I	J	K	KL	L	H	KD	KG
225M	225	455	178	155.5	25	-	80	95	130	919.5	610	80	540

FRAME	MOTOR				SHAFT EXTENSION							BEARING		GREASE	
	M	N	R	XB	Z	KA	Q	QR	S	T	U	W	D-END	6316	2077P
225M	436	391	444.5	149	19	145	140	2	75	12	7.5	20	N-END	6213ZZ	LRL3

MRA5224A	6	3	75 kW	440V	60	1170	CONT.
TYPE	POLES	PH	OUTPUT	VOLT	HZ	RPM	RATING

F	123A	JEC-37-1979	410 kg
INSUL	AMP	RULE	WEIGHT

6本4-F  
1985年製  
両回転可能

CUSTOMER: \_\_\_\_\_

VIA: \_\_\_\_\_

APPLICATION: \_\_\_\_\_

W.NO. \_\_\_\_\_

Date	Name
Drawn	
Checked	
Revisions	

Fuji Electric Co., Ltd

SU568939

d